

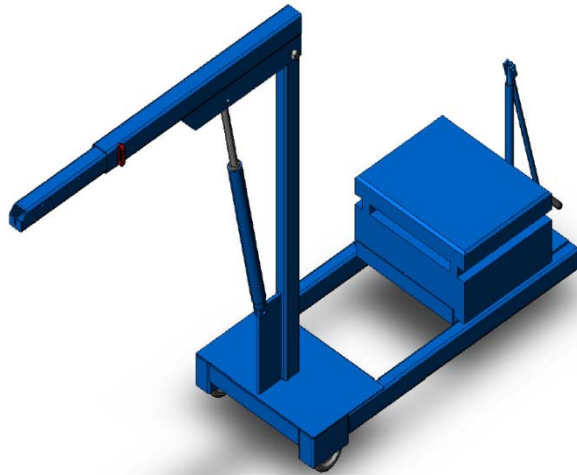

David Round & Son, Inc.  
Ruger Division  
10200 Wellman Rd  
Streetsboro, OH 44241  
Phone: 330-656-1600  
Fax: 330-656-1601  
info@davidround.com  
www.rugerindustries.com

## Ruger® HP1000R



### HP1000R

- 1000 lb. Capacity
- Reversed based allows for easier access to loads

### OPTIONAL ACCESSORIES

- Floor Lock - Direct Bolt-On
- Polyurethane Wheels - Direct Bolt-On
- Steel Wheels - Direct Bolt-On
- Power-Pak - Direct Bolt-On AC/DC Operated Hydraulic Lifting
- Swivel Boom - Limited Swing Motion Design
- Manual Hand Winch - Rated for Lifting Design

Meets ASME PALD standards  
for shop cranes.  
Conforms to ANSI Z535 standards.

### Standard Features

- Meets Ruger's structural engineering standards for 150% of rated lifting capacity
- Counterbalanced units are built to exceed 125% stability factor
- Double action manual hand pump operation
- Built-in hydraulic overload relief valve
- Needle type release valve permits pin-point control over lowering and holding of the heaviest or lightest loads
- Adjustable built-in telescopic boom
- Phenolic wheels with sleeve bearings
- Swivel hook with safety latch
- Steel construction & standard Ruger blue paint

Prices, specifications, and options are subject to change without notice. All Ruger products are shipped F.O.B. Streetsboro, OH 44241



David Round & Son, Inc.  
 Ruger Division  
 10200 Wellman Rd  
 Streetsboro, OH 44241  
 Phone: 330-656-1600  
 Fax: 330-656-1601  
 info@davidround.com  
 www.rugerindustries.com

**MODEL: HP1000R**

Load Capacity      1000 lbs

**Figure 1**

