



David Round, Inc.  
Ruger Division  
10200 Wellman Rd  
Streetsboro, OH 44241  
Phone: (330) 656-1600  
Fax: (330) 656-1601  
www.rugerindustries.com

ADJUSTABLE

HYDRAULIC

POWERFUL

VERSATILE

## FP1000R

- **1000 lb. Capacity**
- **Forward and reverse speed control for moving loads quickly, easily, and safely**
- **Counterbalanced with no legs out front**

### ACCESSORIES

- Wired Pendant
- Remote Control Pendant
- 24 V. Industrial Quick-Change Battery System  
(add 6" to overall length)
- Power In/Out Boom
- Sealed Maintenance Free Battery Pack

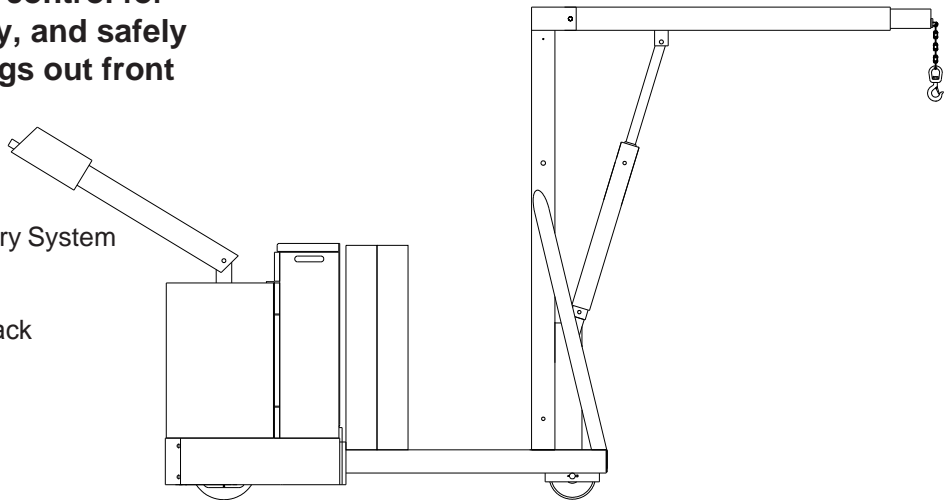

### STANDARD FEATURES

- Meets Ruger's engineering standards of 150% structural overload of maximum rated capacity
- Built-in hydraulic overload relief valve
- Polyurethane drive wheel and load wheels
- Manual extension boom for more reach and height
- Infinity Variable Speed Control
- Solid State Circuitry
- 225 amp/hr batteries and 25 amp, 24 volt on board charger
- Dynamic brake
- Key lock and battery condition indicator/hour meter

Prices, Specifications, and Options are subject to Change Without Notice.

All Ruger products are shipped F.O.B. Streetsboro, Ohio 44241

FAX: (330) 656-1601

E-mail: [info@davidround.com](mailto:info@davidround.com)

The FP1000R is ideal for industrial and large vehicle maintenance applications. Tested and exceeds ANSI/ASME PALD standards. Meets ANSI Z.535



David Round, Inc.  
 10200 Wellman Rd  
 Streetsboro, OH 44241  
 Phone: (330) 656-1600  
 Fax: (330) 656-1601  
 www.rugerindustries.com

**ADJUSTABLE**

**HYDRAULIC**

**POWERFUL**

**VERSATILE**

**MODEL: FP1000R**

Model .....	FP1000R
Max. Capacity .....	1000 lbs
Overall Base Length .....	57"
Overall Length .....	99"
Overall Width .....	34"
Overall Height .....	64"
Boom Reach Retracted .....	42"
Boom Reach Extended .....	54"
Main Boom Height (lowest position) .....	24"
Main Boom Height (highest position) .....	88-1/2"
Ext. Boom Height (lowest position) .....	16"
Ext. Boom Height (highest position) .....	97"
Load Wheels .....	6"

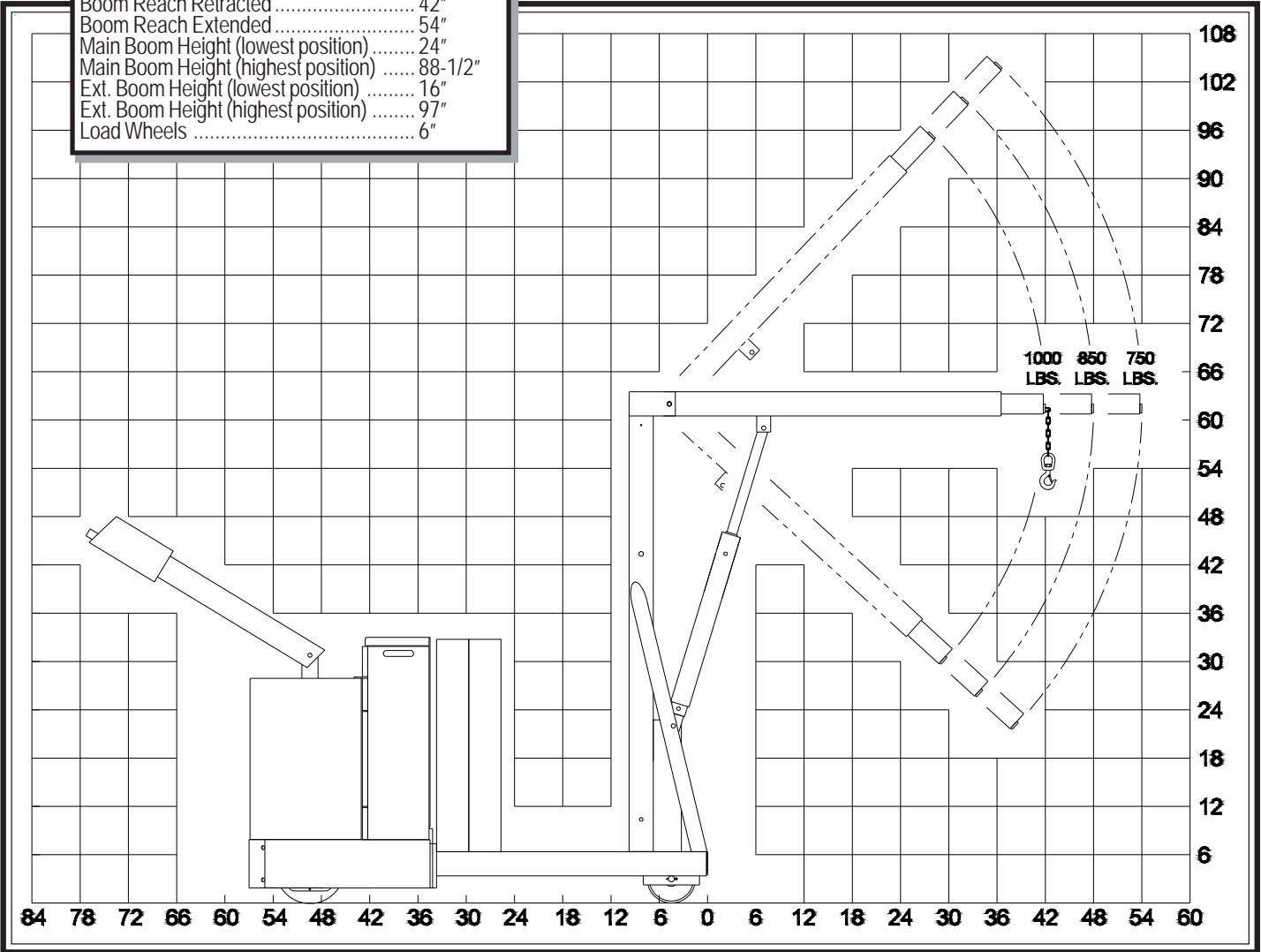

**NOTE: Ruger can modify any standard dimensions to meet specific customer needs.**