



David Round & Son, Inc.
Ruger Division
10200 Wellman Rd
Streetsboro, OH 44241
Phone: 330-656-1600
Fax: 330-656-1601
info@davidround.com
www.rugerindustries.com

Ruger® 10CBW

10CBW

- 1000 lb. Capacity
- Counterbalanced
- Manual Winch with Brake

OPTIONAL ACCESSORIES

- Polyurethane Wheels - Direct Bolt-On
- Steel Wheels - Direct Bolt-On
- Swivel Boom - Limited Swing Motion Design
- Available in Stainless Steel Construction

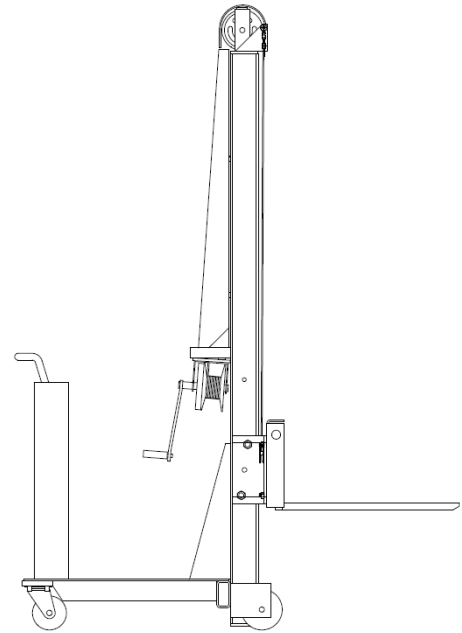

Meets ASME PALD standards
for shop cranes.
Conforms to ANSI Z535 standards.

Standard Features

- Meets Ruger's structural engineering standards for 150% of rated lifting capacity
- Counterbalanced units are built to exceed 150% stability factor
- Double action manual hand pump operation
- Built-in hydraulic overload relief valve
- Needle type release valve permits pin-point control over lowering and holding of the heaviest or lightest loads
- Adjustable built-in telescopic boom
- Steel wheels with sleeve bearings
- Swivel hook with safety latch
- Steel construction & standard Ruger blue paint

Prices, specifications, and options are subject to change without notice. All Ruger products are shipped F.O.B. Streetsboro, OH 44241



David Round & Son, Inc.
Ruger Division
10200 Wellman Rd
Streetsboro, OH 44241
Phone: 330-656-1600
Fax: 330-656-1601
info@davidround.com
www.rugerindustries.com

MODEL: 10CBW

Load Capacity 1000 lbs

Figure 1

